

# Small Size – Engineered Plastics

## LS-3 Series – Offers High Reliability, Compact Size and Low Costs in NPT, Straight and Metric Threads

Ideal for shallow tanks or restricted spaces, or for any low-cost, high volume use. LS-3 Series are available in FDA compliant materials, consult GEMS for details.

LEVEL SWITCHES – SINGLE POINT

Polysulfone Float



For water based liquids, with limited use in oils and chemicals.

Polypropylene Float (Hollow)



Features a low specific gravity float offering broad chemical compatibility.

Polypropylene Float (Solid)



With Polypropylene stem and float, switch offers broad chemical compatibility.

Buna N Float



Ideal for oils and fuels.

ALL-PVDF



Stem and float of corrosion-resistant PVDF for ultra-pure applications.

New 3/4" Polypropylene Float



See next page for details.



RoHS Compliant

All LS-3 Series level switches featured on this page and the next are in compliance with EU-directive 2011/65/EC.

### Common Specifications

**Approvals:** U.L. Recognized – File No. E45168; CSA Listed – File No. 30200. CE Declaration Available Upon Request.

NSF materials are NSF 169 Standard compliant. For NSF approved level switches contact Gems.

RoHS – In compliance with EU-directive 2011/65/EC requirements for chemicals and substances.

**Switch SPST:** 20 VA, 120-240 VAC. Units are shipped N.O. unless otherwise specified. Selectable, N.O. or N.C., by inverting float on unit stem.

### Dimensions – 1" Float Models only

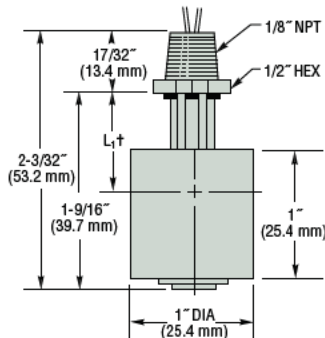

† L<sub>1</sub> = Actuation Level (see chart below)

Electrical Termination	Alternate Mountings		
	3/8"-16 Straight Thread	G1/8" 1/8"-28 BSP	M12x 1.75 Straight Thread
Lead Wires			
Cable			

**How To Order – Select Part Number based on specifications required.**

Stem and Mounting Material	Float Material	Float Dia.	Actuation Level <sup>†</sup>	Min. Liquid Sp. Gravity	Pressure Max. @ 70°F (21°C)	Operating Temperature	Mounting Type	Electrical Termination	Part Number
Polysulfone	Polysulfone	1"	3/4" (19.0 mm)	.75	50 psi (3 bar)	-40°F to +225°F (-40°C to +107°C)	1/8" NPT	Lead Wires	42295 ⚡
Polypropylene <sup>2</sup>	Polypropylene (Hollow)	1"	13/16" (20.6 mm)	.60	50 psi (3 bar)	-40°F to +225°F (-40°C to +107°C)	1/8" NPT	Lead Wires	142505 ⚡
							3/8"-16	Lead Wires	171517 ⚡
							G 1/8"-28	Cable	171518
Polypropylene <sup>3</sup> NSF Std. 169 (Kynar float retaining clip)	Polypropylene <sup>3</sup> (Hollow) NSF Std. 169	1"	13/16" (20.6 mm)	.60	50 psi (3 bar)	-40°F to +225°F (-40°C to +107°C)	M12x1.75	Cable	189739
							1/8" NPT	Lead Wires	209475
							3/8"-16	Lead Wires	209455
Polypropylene <sup>2</sup>	Polypropylene (Solid)	1"	9/16" (14.3 mm)	.90	150 psi (10 bar) @ 68°F (20°C)	-40°F to +150°F (-40°C to +66°C)	1/8" NPT	Lead Wires	116826 ⚡
							3/8"-16	Lead Wires	171514 ⚡
		3/4"	7/16" (11.1 mm)	.95	Atmospheric	-40°F to +176°F (-40°C to +80°C)	M12x1.75	Cable	189787
							1/8" NPT	Lead Wires or Cable	201540 ⚡
Nylon	Buna	1"	13/16" (20.6 mm)	.45	150 psi (10 bar)	-40°F to +250°F (oil) (-40°C to +121°C [oil])	1/8" NPT	Lead Wires	162745 ⚡
							M12x1.75	Cable	189786
		3/4"	11/16" (17.5mm)	.85	150 psi (10.3 bar)	-40°F to +176°F (water) (-40°C to +80°C [water])	1/8" NPT	Lead Wire	177818
PVDF	PVDF	1"	1/2" (12.7 mm)	.86	50 psi (3 bar)	-40°F to +250°F (-40°C to +121°C)	1/8" NPT	Teflon Jacketed Lead Wires	173250 ⚡

**Notes:**

1. Based on a liquid specific gravity of 1.0.
2. All Polypropylene units carry a Kynar retaining clip. Accessories Available in OEM Quantities: Jam Nut, Gaskets, and Sloss Shields.
3. NSF 169 Approved unit, for water use only.

⚡ – Stock Items.

## 3/4" Diameter Floats for Tiny Tanks

### Our smallest LS-3 yet!

- ▶ Reliable alternative to more expensive electronic sensors.
- ▶ Fits smaller devices. Less material, lower cost.
- ▶ Proprietary float more buoyant than competitors.

Small yes, but with BIG performance. No other 3/4" float switch on the market matches our LS-3 specs. These units are ideal for potable water, medical devices and other compact appliances, such as printers. Gems proprietary float enables use in lighter-than-water fluids. NSF/ FDA compliant models available at your request. Please consult factory.

### Specifications

<b>Wetted Material</b>	
<b>Stem and Mounting</b>	
P/N 201540	Polypropylene with Kynar retaining clip
P/N 177818	Nylon
<b>Float</b>	
P/N 201540	Polypropylene
P/N 177818	Buna-N
<b>Magnet</b>	
P/N 201540	Ceramic
<b>Operating Temperature, Max.</b>	
P/N 201540	212°F (100°C)
P/N 177818	250°F (121°C) oil, -40°F to +176°F (-40°C to +80°C)
<b>Pressure, Max.</b>	
P/N 201540	Atmospheric
P/N 177818	150 psi (10.3 bar)



### Dimensions

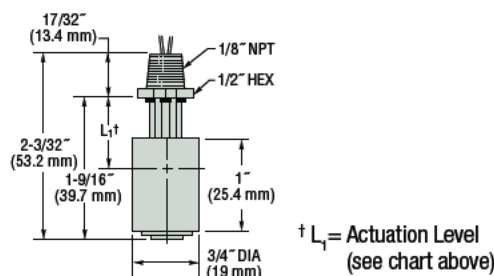

### Order by Part Numbers:

- LS-3, 3/4" Polypropylene Float: 201540
- LS-3, 3/4" Buna-N Float: 177818

**LEVEL SWITCHES – SINGLE POINT**

## Unique Features Make These LS-3 Models Special

These small switches feature unique configurations for special applications.

LEVEL SWITCHES – SINGLE POINT

Part No. 142545  
With Slosh Shield



Cut-away version shown

Compact, all-polypropylene switch with slosh shield is ideal for use with turbulent liquids in small tanks. FDA compliant materials.

Part No. 46999  
Bottle Level



For external mounting on tanks too small to accommodate internally mounted switches. (See note below)

Part No. 76707  
For Low Level

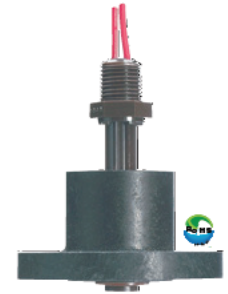

For detecting levels as low as 5/8" from tank bottom. Use in water, some oils and chemicals.

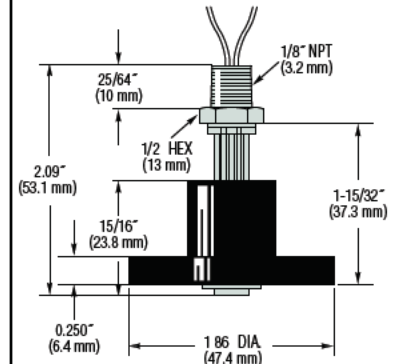
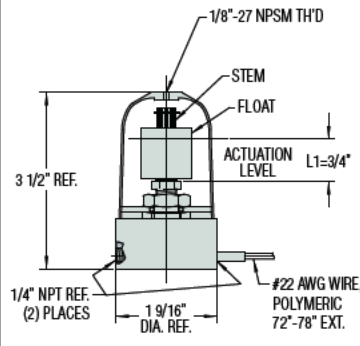
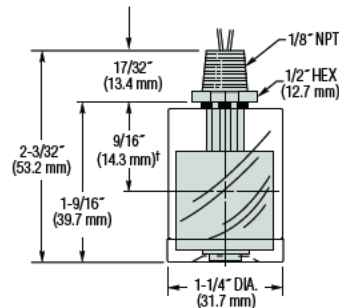

Order By Part Number	142545 ⚡	46999 ⚡	76707 ⚡
<b>Materials</b>			
Stem and Mounting	All Polypropylene (Including Shield <sup>4</sup> )	Polysulfone	All Polysulfone (Including Collar)
Float	Polypropylene (Solid)	Polysulfone	Buna N
Other Wetted	—	Brass, Aluminum, Polycarbonate, Viton A	Epoxy
Min. Liquid Sp. Gr.	.90	.75	—
Operating Temperature	-40°F to +150°F (-40°C to +65.6°C)	-40°F to +120°F (-40°C to +48.9°C)	-40°F to +180°F (-40°C to +82.2°C)
Pressure, PSI, Max. <sup>3</sup>	150	50	
Switch <sup>1</sup> , SPST	20 VA, N.C./N.O. Dry <sup>2</sup>	20 VA, N.C. Dry	
Electrical Termination	No. 22 AWG, 22" L., PVC Lead Wires	No. 22 AWG, 72" L., Polymeric Lead Wires	No. 22 AWG, 72" L., PVC Lead Wires

Notes:

- See "Electrical Data" on Page X-5 for more information.
  - Switch operation is selectable, N.O. or N.C., by inverting the float on the unit stem.
  - Maximum pressure at 70°F (21°C).
  - Consult factory for other available materials.
- † L<sub>a</sub> = Switch actuation level, nominal (based on a specific gravity of 1.0).

Note: LS-3 Series Bottle Level Switch is also available with any of the float materials shown on opposite page. Contact GEMS for correct part number.

⚡ – Stock Items.